

Great
for
*Retrofits



Clarus

Swing Door

Slim Design with Great Visibility
& Energy Efficient Performance



*For case manufacturer retrofit only. Will not retrofit on walk-in cooler/freezer.

Clarus Swing Door

Slim Design with Great Visibility
& Energy Efficient Performance

Anthony's Clarus is a full vision lightweight, durable swing door that makes shopping easy and reduces energy consumption



Features

- Slim design includes a spacious viewing area, thin perimeter rails, zero-heat narrow glass pack, and stylish Arch handle that allows shoppers to easily see and access merchandise
- Zero-heat door and frame system for normal temperature applications saves up to 65% on energy costs
- Optimax Pro 24 LED lights save up to 75% on energy costs, provide superior illumination, and are a perfect lighting solution when retrofitting glass doors on open multi-deck refrigerated display cases
- Gravity hinge provides smooth door movement and a detent props the door open, allowing easy access for product selection and restocking

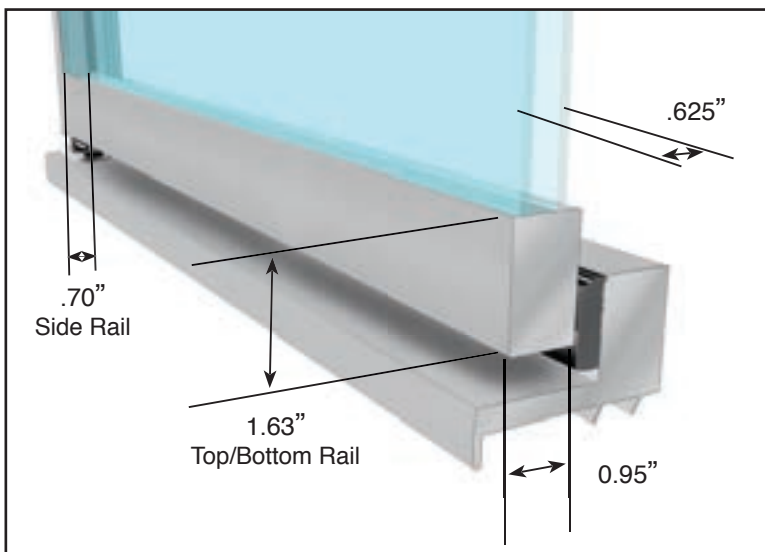

Applications

Closing open multi-deck refrigerated display cases

Standard Features

Zero-heat Door and Frame System	
Zero-heat Insulated Glass Pack	.625" (15.875mm) Thick 2 Pane Argon Gas Filled Tempered Warm Edge Spacer
R-value	2.3 (hr-ft ² -F/Btu)
U-value	.44 (W/m ² .K)
Total Door Thickness	.95" (24.13mm)
Vertical Door Rails	.70" (17.78mm)
Top & Bottom Rails	1.63" (41.40mm)
Lighting	Optimax Pro 24 LED
Arch Handle	15.88" (403mm)
ISO 23953 Class - 3M1	
*Dewpoint	63°F
Gravity Hinge	
Reversible Swing	
Magnetic Seal	Top & Bottom
Cycle Reliability Tested	500,000
Glass Seal Warranty	10 Years
Parts Warranty	12 Months

Options

Finish	Satin Silver or Black
Handle	"J" Type
Anti Fog Film	
Heated Frame	

**Engineered for stores with ambient conditions not to exceed 75° and 55% relative humidity. Due to engineering improvements, specifications may change without notice.

*For case manufacturer retrofit only. Will not retrofit on walk-in cooler/freezer.



ANSI/NSF 2



CLARUS 06-14

For more information, call 800-772-0900, visit www.anthonynintl.com or email sales@anthonynintl.com

