

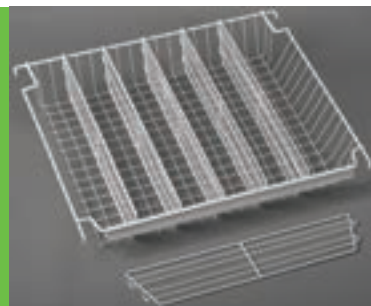

Enertech II™ Doors

Energy Efficient and Fast Payback



Enertech II™ Doors

Energy Efficient and Fast Payback

The Enertech line is one of Anthony's more energy-efficient cooler and freezer systems; with energy-free cooler doors, energy efficient frames, and a variety of options to customize for specific conditions. Energy savings offer reduced operating costs and a fast payback on investment.

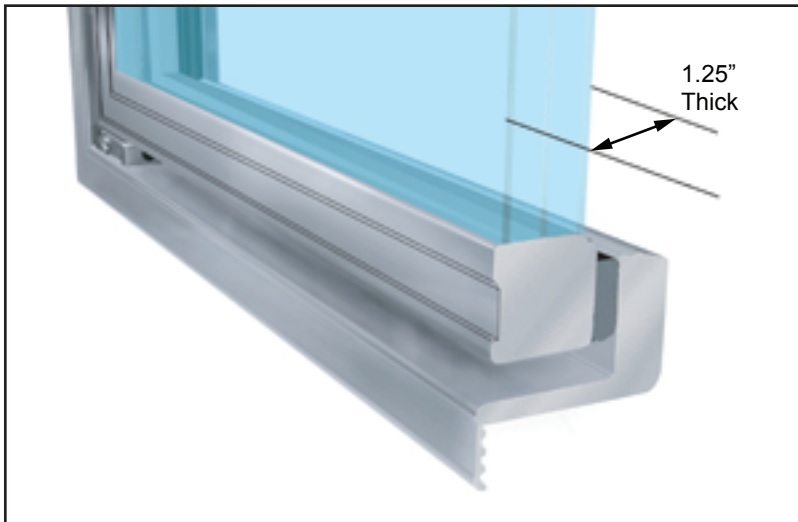

1.25" Thick

Enertech II 1-1/4" Glass Pack

Standard Door Sizes

23 x 63	30 x 63
23 x 72	30 x 66
26 x 63	30 x 72
26 x 72	30 x 80

Accessories

- 27" and 36" deep shelving
- Mobile deli and beverage racks
- Baskets

Walk-In Door Sizes

30 x 80
36 x 80

Glass Options

- 1/3 glass, 2/3 panel
- Full glass
- Full panel

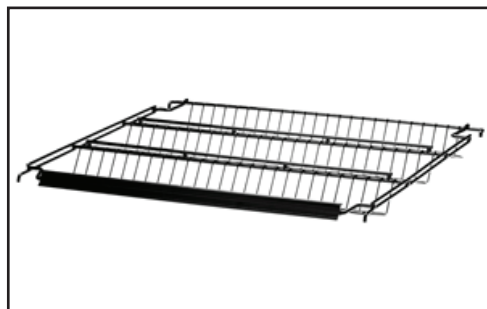

Deli Rack



Cylinder Lock



Optimax Pro 24 LED

Applications

Cooler and freezer doors

Standard Features

- Energy-free cooler doors
- 3-pane non-heated low thermal conductivity sealed glass unit
- T-8 Lighting
- Polished aluminum, Black, Silver Satin & Gold Anodized finish
- Front-mount handle
- Reversible doors with top hold-open and 90° door stop
- Magnetic door gaskets
- Self-closing, one-step, adjustable tension doors
- Warm edge technology
- Matching walk-in entry doors

Options

- Factory-installed manual cylinder locks
- Low E glass
- Heated glass for high humidity areas
- Factory installed door guards, push bars and kickplates
- Full length handle

Enertech II Retrofit for Old Swingline 3 Frames Only

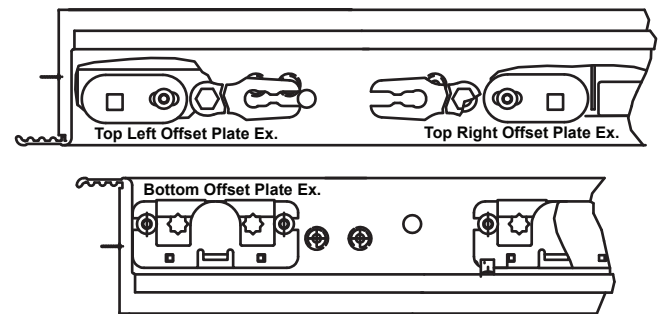

Top and bottom offset plates required for Enertech II installation into Ardco frame.