







## **Standard Shelving Installation Instructions**

99-18880-I001\_B

Copyright © 2011 by  Anthony

ALL rights reserved. Information in this document is subject to change without notice. Companies, names and data used in examples herein are fictitious unless otherwise noted. No part of this document may be reproduced or transmitted in any form or by any means, electronic or mechanical, for any purpose, without express permission of Anthony Manufacturing Co., Inc.

Anthony products identified in this manual are designed and certified to meet  or  for safety, and  for sanitation standards.

European products meet  requirements.

Each customer is responsible for final site approval.

---

## TABLE OF CONTENTS

<b>PRELIMINARY CONSIDERATIONS STANDARD SHELVING INSTALLATION INSTRUCTIONS</b> .....	<b>1</b>
Safety .....	1
Tools .....	1
Tips .....	1
<b>VERTICAL AND HORIZONTAL CAN AND BOTTLE DISPENSER AND MERCHANDISER</b> .....	<b>2</b>
Installation Instructions .....	2
<b>INSTALLATION INSTRUCTIONS STANDARD CORNER SHELVING</b> .....	<b>4</b>
<b>BASKET SHELF INSTRUCTIONS</b> .....	<b>6</b>
<b>MILKMASTER INSTRUCTIONS</b> .....	<b>7</b>
<b>WINE SHELF INSTRUCTIONS</b> .....	<b>7</b>
<b>DELI RACK ROLL-A-WAY INSTRUCTIONS</b> .....	<b>7</b>
To install Deli baskets: .....	8
<b>VERTICAL CAN AND BOTTLE ROLL-A-WAY INSTRUCTIONS</b> .....	<b>9</b>
<b>DOUBLE AND SINGLE DOOR DELI-VUE INSTALLATION INSTRUCTIONS</b> .....	<b>10</b>
Install Deli-Vue Hooks. ....	11
Basket Installation.....	11
<b>HALF-DOORF DELI-VUE INSTALLATION INSTRUCTIONS</b> .....	<b>12</b>
Install Deli-Vue Hooks .....	13
<b>WINE-VUE INSTALLATION INSTRUCTIONS</b> .....	<b>14</b>
To Install Wine-Vue .....	14
Top Shelf .....	15
Wine Cradle .....	15
<b>STANDARD SHELVING INSTALLATION INSTRUCTIONS</b> .....	<b>16</b>
Shelf Posts.....	16
Shelf Installation .....	18
Catalog Shelf Sizes .....	20
Shelf Dimensions.....	20

**PRELIMINARY CONSIDERATIONS STANDARD SHELVING  
INSTALLATION INSTRUCTIONS**

**Safety**

Proper safety equipment includes:



**safety glasses**



**work gloves**



**work shoes**



**NOTE: TURN OFF ALL ELECTRICAL POWER PRIOR TO BEGINNING WORK ON THE DOOR OR ON ANY ELECTRICAL. USE EXTRA CAUTION WHEN WORKING WITH OR AROUND THE DOOR GLASS PACKAGE.**

**NOTE: DO NOT USE POWER TOOLS FOR THE FOLLOWING PROCEDURES**

**Tools**

Tools required for this procedure include:

- #2 Phillips-head screwdriver
- Flat-head screwdriver
- Needle-nose pliers
- Rubber or plastic mallet
- $\frac{7}{16}$ " and  $\frac{1}{2}$ " Hand Wrench
- $\frac{5}{32}$ " Hex Key
- Wire stripper and cutter
- Razor Knife

**Tips**

- Complete replacement of wire assemblies is recommended whenever required. Splice wires only if necessary using proper materials such as, electrical tape, wire nuts, flux core solder and heat shrink.
- Keep doors and frames clean for product efficiency. This can also help reduce energy consumption and potential health hazards.
- Whenever binding gasket or plastic parts, use food grade silicone.
- Always use the correct tool for the job to be performed. This ensures proper installation and minimizes safety risks.

- If there is any doubt about the work to be performed, consult with a certified technician or Anthony representative.
- Preventative maintenance is recommended to ensure product longevity.

## VERTICAL AND HORIZONTAL CAN AND BOTTLE DISPENSER AND MERCHANDISER

### Installation Instructions

1. Install front prongs of the can or bottle dispenser shelf in front post slots with the shelf's back end titled up at an angle. Refer to [Figure 1](#) and [Figure 2](#).

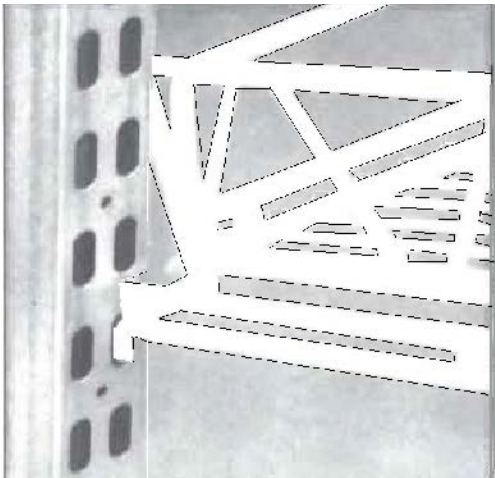

Figure 1

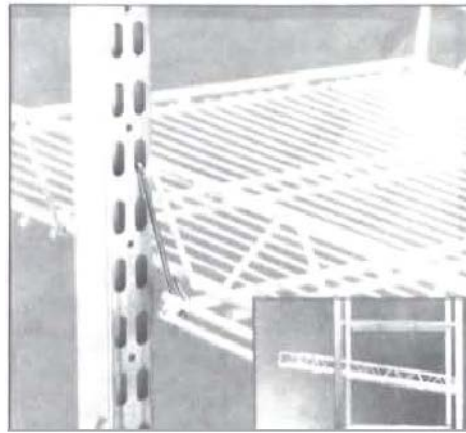

Figure 2

2. Space shelves for desired product heights. Pull swivel hooks ([Figure 3](#)) attached to rear of dispensers into slots on rear posts and drop rear of dispenser down. For best results with gravity feed dispenser, position dispenser at 15 degree angle with back end of dispenser installed approximately four slots higher than front of shelf. Refer to [Figure 4](#).

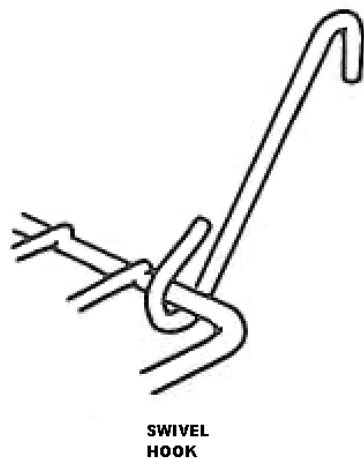

Figure 3

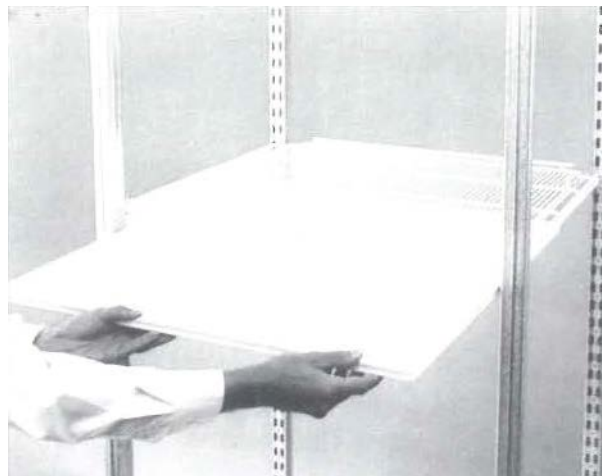
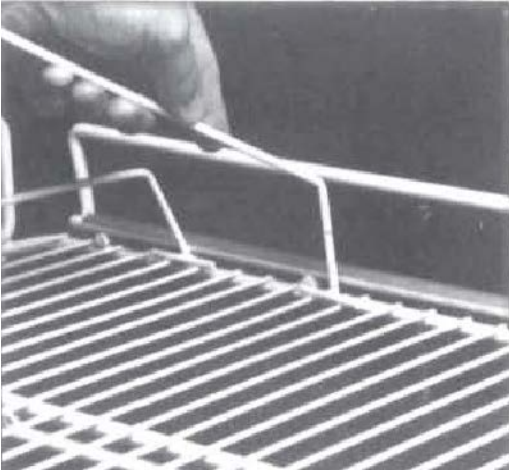

Figure 4

3. Dividers can be positioned at any point along the shelf. To install, insert the front prong between the price tag molding bars. [Refer to Figure 5](#) .



**Figure 5**

4. Flex the divider and hook the other end over the bar. [Refer to Figure 6](#) .

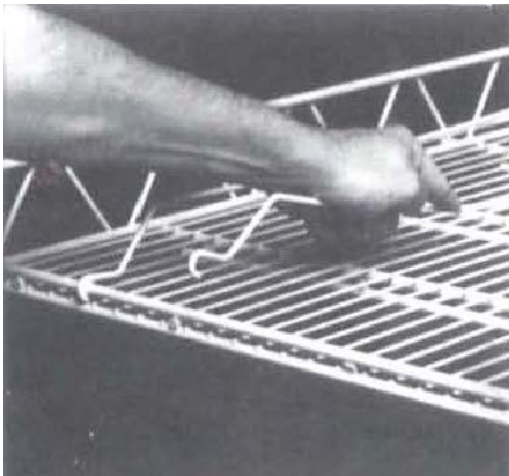

**Figure 6**

5. Milk drip pan for dispensers slides in and out of “L” brackets on bottom of shelf dispenser

## INSTALLATION INSTRUCTIONS STANDARD CORNER SHELVING

1. Corner shelving is designed to go between two-sided walk-ins.
2. Corner shelving as a rule is used between an "L" shaped walk-in with the doors on the outside of the "L". Refer to [Figure 7](#).

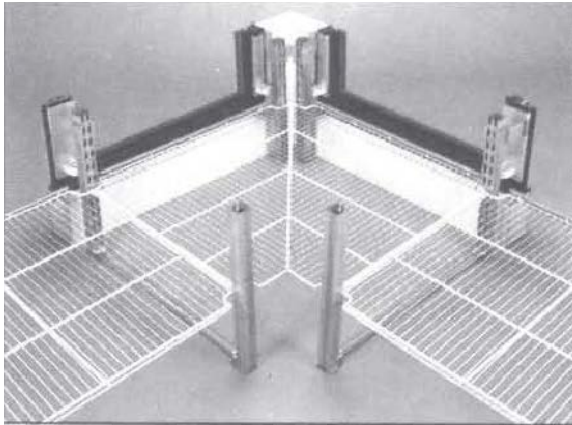

Figure 7

3. Corner shelving is designed to cover the two doors in the inside corner of the "L".
4. Installation of corner shelving is the same as standard shelving except some corner shelves will have more posts. Refer to [Figure 8](#), [Figure 9](#) and [Figure 10](#).

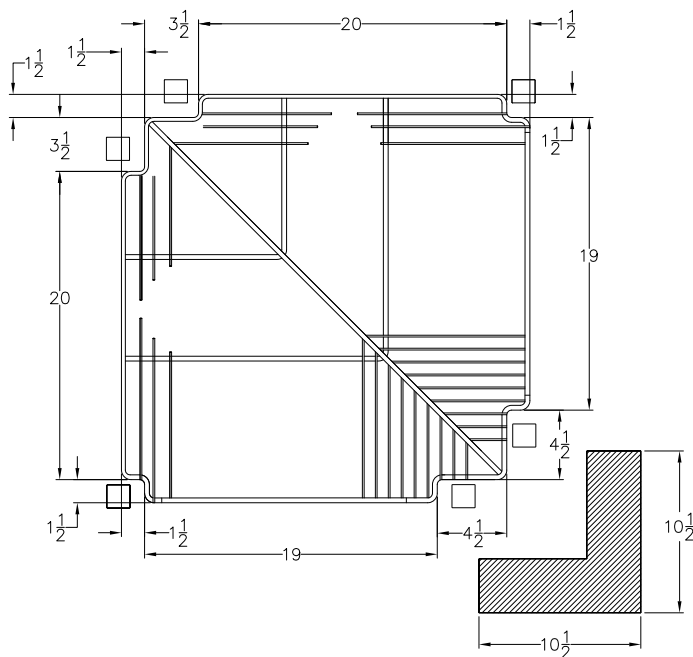

Figure 8 23" Door

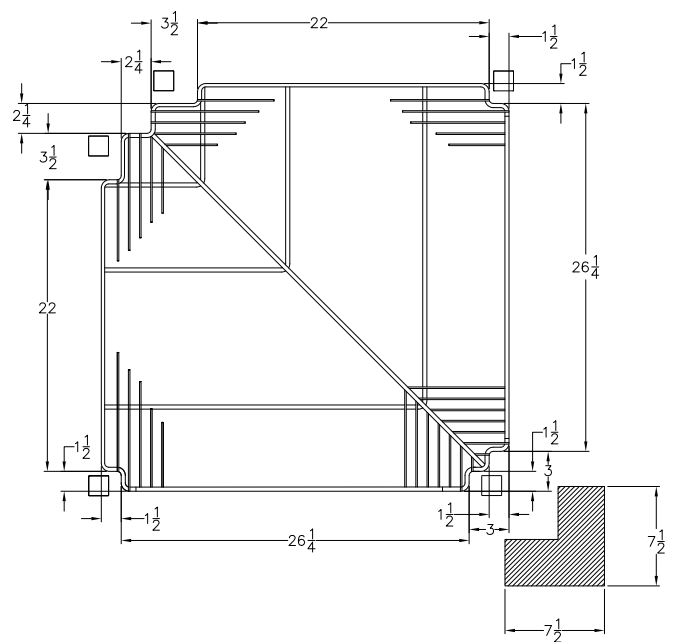

Figure 9 26", 28" and 30" Door

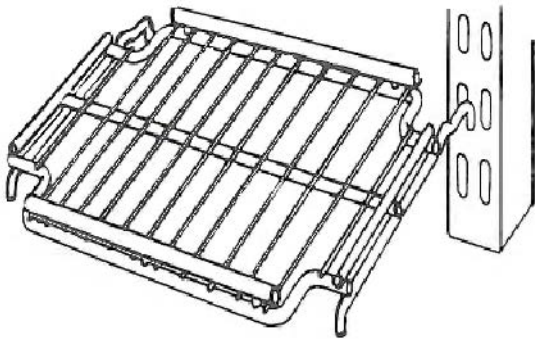

Figure 10

5. The standard corner shelf:
  - a. 23" doors take a 10-1/2" X 10-1/2" corner measured from the outside of walk-in corner to start of net opening both ways from corner.
  - b. 26", 28" and 30" doors take 7-1/2" X 7 -1/2" corner measured the same as 23" doors. [Refer to Figure 11](#) .

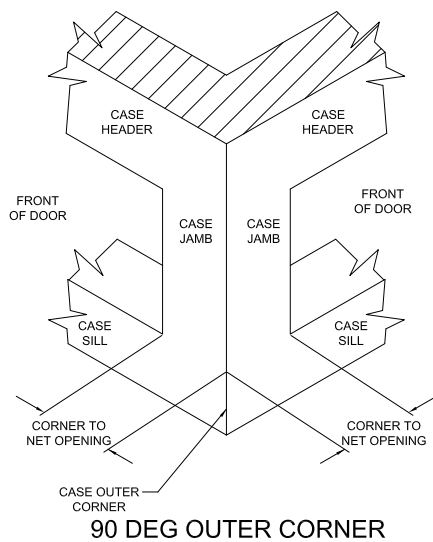

Figure 11

6. Custom corner shelves available upon request.



## BASKET SHELF INSTRUCTIONS

1. Refer to [Figure 12](#) and [Figure 13](#) for rear.

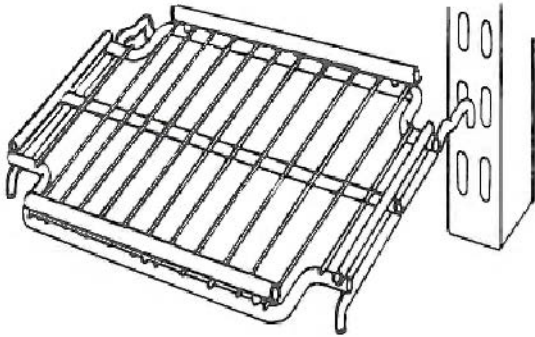

Figure 12

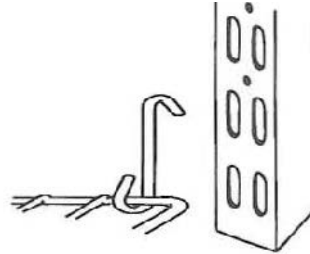

Figure 13

2. Clip-on dividers. Dividers clip on front and rear shelf wires. Refer to [Figure 14](#).

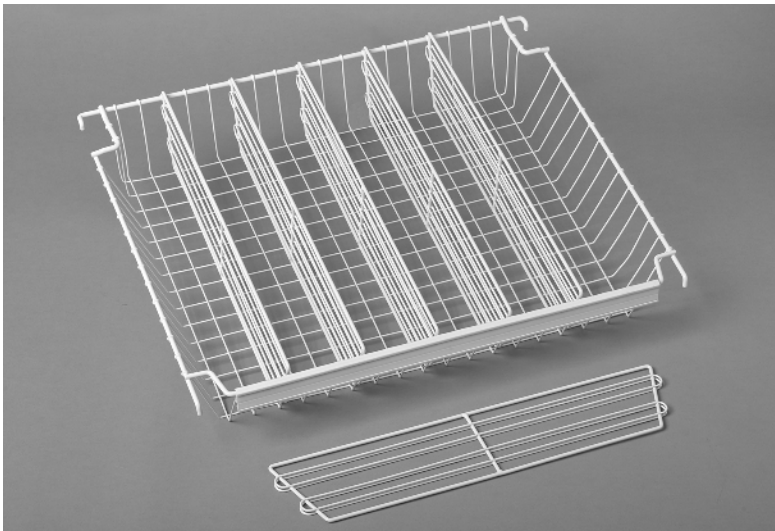

Figure 14

## MILKMASTER INSTRUCTIONS

1. Roll in Milkmaster is 29-1/2" wide by 37" deep by 76" wide.
2. Milkmaster shelving installs the same way as a can and bottle dispenser, except that Milkmaster has its own snap-in place rear product stop. Refer to [Figure 15](#) and [Figure 16](#) for rear

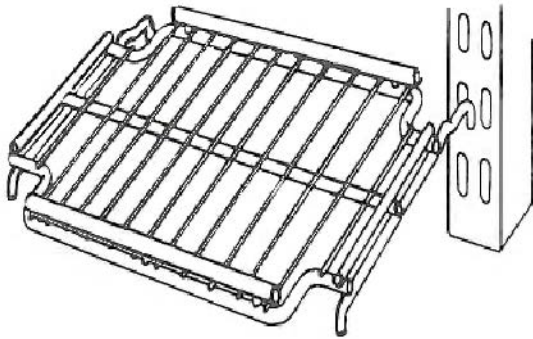

Figure 15

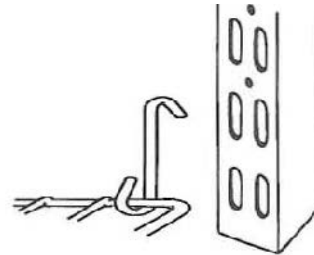

Figure 16

3. Milkmaster bottom drip pan installs into bottom of Roll-A-Way in between the "L" shaped bottom bracket in shelf.

## WINE SHELF INSTRUCTIONS

1. Standard size shelf with raised affixed dividers
2. Shelf accommodates two-bottle depth.
3. TBS. Refer to [Figure 17](#) .



Figure 17

## DELI RACK ROLL-A-WAY INSTRUCTIONS

1. Dimensions are 30-1/2" wide by 27-1/2" deep and 80" tall.
2. Fits behind the all glass pass-thru doors.
3. To push out of way, release unit's front brakes.
4. To install Deli-Vue Hooks, snap "U" bracket on back of hook into webbing groove. Refer to [Figure 18](#) and [Figure 19](#) .

**To install Deli baskets:**

5. Attach Deli-Vue Shelf Clip to webbing. Refer to Figure 18 .
6. Then attach basket to Deli-Vue Shelf Clip.

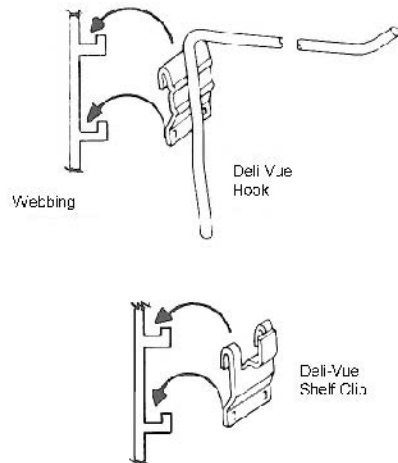

**Figure 18**



**Figure 19**

## VERTICAL CAN AND BOTTLE ROLL-A-WAY INSTRUCTIONS

1. The vertical can and bottle Roll-A-Way goes behind any Anthony all glass pass-thru doors. Refer to [Figure 20](#) and [Figure 21](#)
2. Install Roll-A-Way before installing frames and doors.
3. Dimensions of Roll-A-Way are 30-1/2" X 27-1/2" X 80" tall.
4. Install shelving the same way as Standard shelving instructions. Refer to [STANDARD SHELVING INSTALLATION INSTRUCTIONS](#).
5. To remove Roll-A-Way, release front brakes.

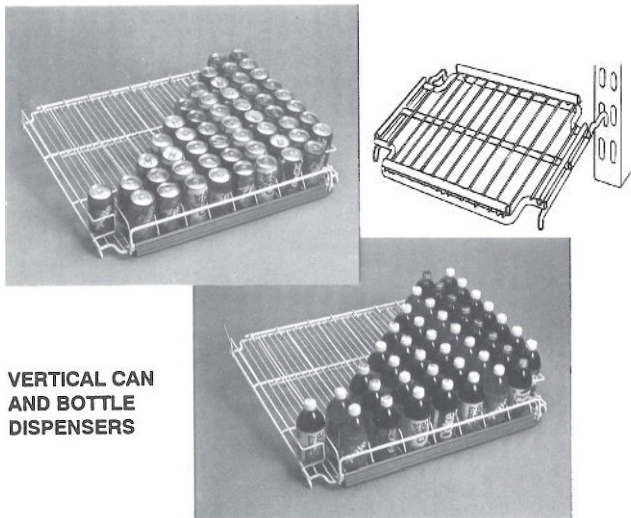
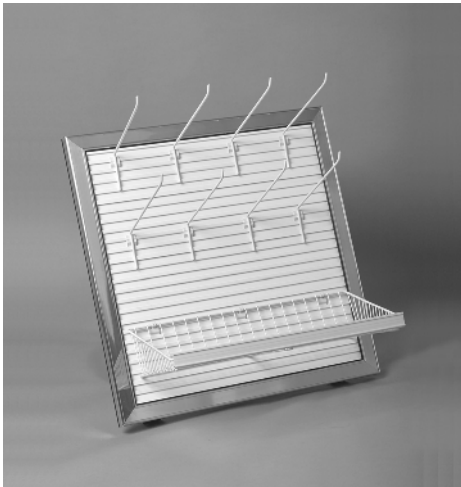

Figure 20



Figure 21

DOUBLE AND SINGLE DOOR DELI-VUE INSTALLATION INSTRUCTIONS



1. Refer to Figure 22 and Figure 23 .

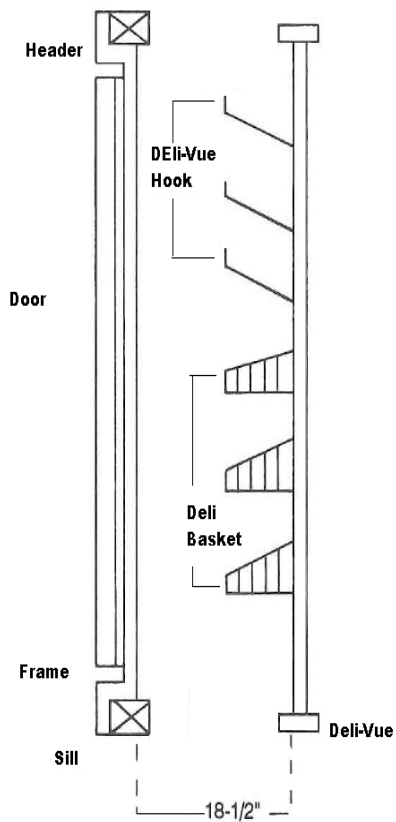
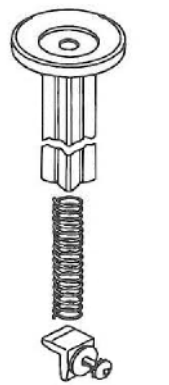
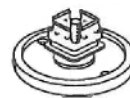

Figure 22



Spring Loaded  
Deli-Vue  
Upright



Deli-Vue  
Foot

Figure 23

2. Install Deli-Vue 19-1/2" in from back of frame plastic to front of Deli-Vue upright.

3. Overall depth of Deli-Vue assembly is 14-1/2".
4. Deli-Vue baskets should sit approximately 3"-4" in from back of frame plastic.
5. Standard assembly fits ceiling heights of 82-1/2" to 96-1/2".
6. To install Deli-Vue:
  - a. Loosen screws (CCW) at top back of Deli-Vue upright
  - b. Push adjustable spring rod insert up to ceiling
  - c. Re-tighten screws
  - d. Repeat [step a.](#) thru [step c.](#) on the other side.

**NOTE: Make sure Deli-Vue is level and plumb before tightening screws. There is an adjustable foot on bottom of Deli upright for leveling.**

7. Set a basket up to front of Deli-Vue to make sure unit is not too close to break of door.
8. Go back to adjustable spring uprights, and put a screw into access hole in round plate that goes from upright to ceiling. This is a safety precaution. [Refer to Figure 24](#) .

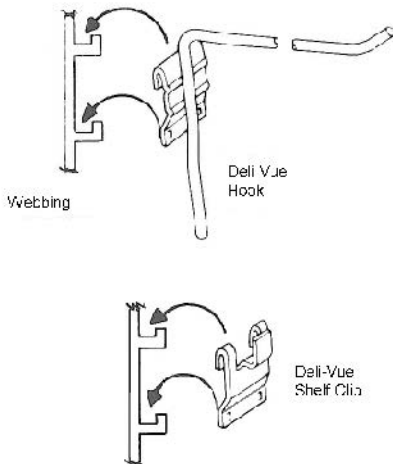

**Figure 24**

**Install Deli-Vue Hooks.**

9. To install Deli-Vue Hooks, snap “U” bracket on back of hook into webbing groove. Space for desired product.

**Basket Installation**

10. shelf into Deli-Vue Shelf Clips.

Basket Depth	Basket Product Area	Deli Peg Length
12"	9-3/4 deep	12"

## HALF-DOORF DELI-VUE INSTALLATION INSTRUCTIONS



1. Attach aluminum stabilizer bars with screws provided to back top end of Deli door

**NOTE: Holes are predrilled.**

2. Locate Half Door Deli 9" in from front of standard shelf (27"). Refer to Figure 25 .

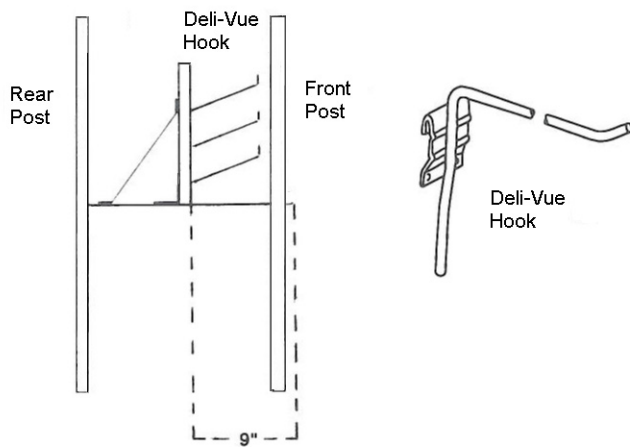

Figure 25



3. Fasten bottom end of stabilizer bars to shelf wires with nuts, bolts, and washers provided. Refer to Figure 26 .

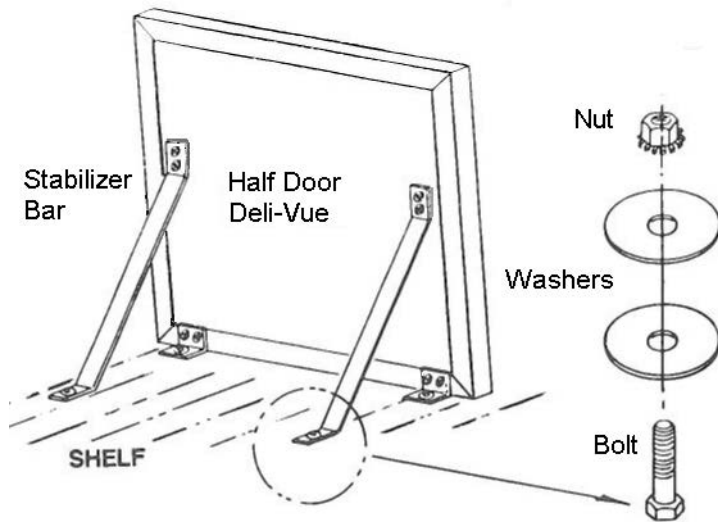

Figure 26

### Install Deli-Vue Hooks

4. Snap "U" bracket on back of hook into webbing groove.

**NOTE: Half-Door Deli-Vue sits on standard 27" deep shelf.**



## WINE-VUE INSTALLATION INSTRUCTIONS

1. Install Wine-Vue (webbing with uprights) 23" in from back of frame plastic to front of Wine-Vue.
2. Overall depth of Wire-Vue assembly is 18". Refer to Figure 27

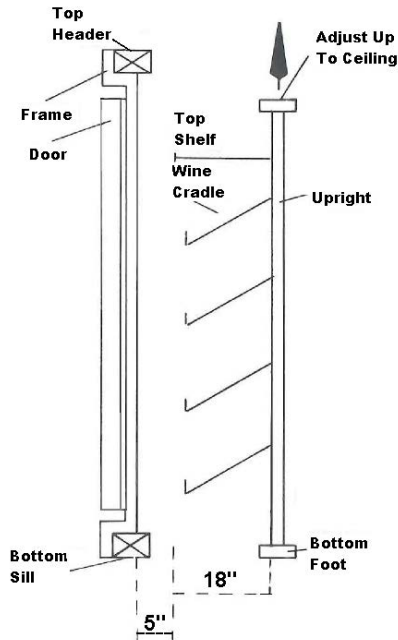

Figure 27

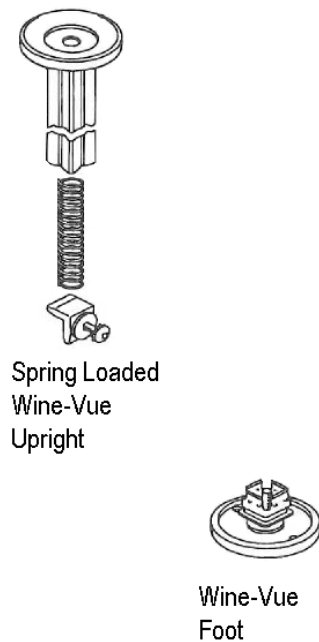

Figure 28

3. Wine-Vue cradles should sit approximately 4"-5" in from back of frame plastic.

### To Install Wine-Vue



4. Loosen screws (CCW) at top back of Wine-Vue uprights.
5. Push adjustable spring rod insert up to ceiling
6. Re-tighten screws.

7. Repeat [step 4](#).thru [step 6](#). on other side.

**NOTE: Make sure Wine-Vue is level and plumb before tightening screw all the way. There is an adjustable foot on the bottom of Wine-Vue upright for leveling.**

8. Set a cradle up to front of Wine-Vue to make sure unit is not too close to glass.
9. Now go back to spring adjustable uprights and put a screw into access hole in top plate that goes from upright to ceiling

**NOTE: This is a safety precaution.**

### Top Shelf

10. Install Deli-Vue Shelf Clips provided

**NOTE: Deli-Vue Shelf Clips insert into grooves in webbing.**

11. Insert shelf into Deli-Vue Shelf Clips.

**NOTE: Use two clips per shelf.**

### Wine Cradle

12. Install Deli-Vue Shelf Clips provided

**NOTE: Deli-Vue Shelf Clips insert into grooves in webbing.**

13. Insert Wine Cradle into Deli-Vue Shelf Clips.

**NOTES:**

1. Use two clips per shelf
- 2, Set Deli-Vue Shelf Clip spacing for desired product

Overall top shelf Depth	<b>Cradle (single bottle depth</b>
15"	14-1/2" deep

---

## STANDARD SHELVING INSTALLATION INSTRUCTIONS

### Shelf Posts

1. Install front shelf posts. [Refer to Figure 29](#)

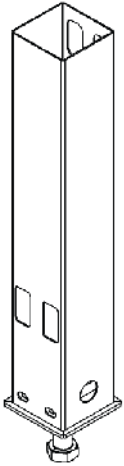

**Figure 29**

2. Fit top and bottom retaining brackets over top post with offset keyway retainer at back of post (Opposite side of post slots). [Refer to Figure 30](#).

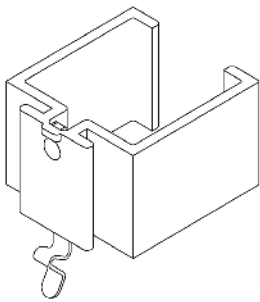

**Figure 30**

3. Post retaining bracket spring slides into female frame post bracket from the top down. Refer to Figure 29 .

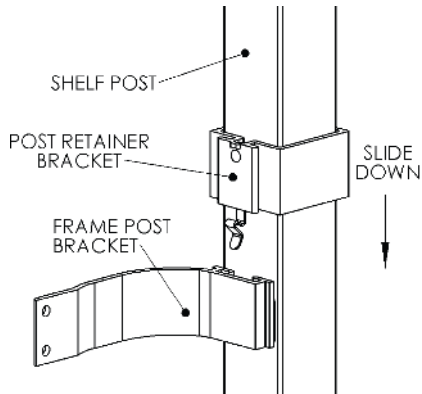

**Figure 31**

4. Slotted holes in front and rear posts now face toward the back wall (inside of case). Refer to Figure 32 .

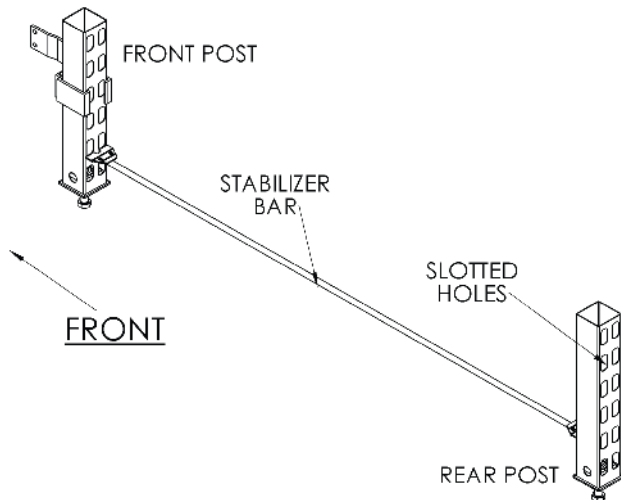

**Figure 32**

5. Install post stabilizer bars ( Refer to Figure 33 ) on the top and bottom of all posts, front to rear, before installing shelves. Stabilizer bars have a forked end that inserts into elongated holes in front and rear posts.

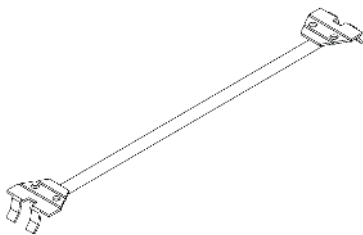

**Figure 33**

**NOTE: Rear Posts have additional holes on seam side for stabilizer.**

- Level front and rear posts at bottom of post. [Refer to Figure 34](#) ..

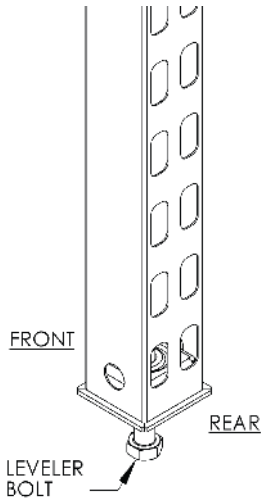

**Figure 34**

## Shelf Installation

**NOTE: SHELF WEIGHT LIMIT OF 200 LBS (90.7 KG).**

**NOTE: INDIVIDUAL POST WEIGHT LIMIT 1050 LBS (476 KG). Posts must have intermediate supports (post locators) installed. Shelf heights to be located for merchandising and load dispersion.**

- Angle/Tilt shelf ( [Refer to Figure 35](#) ) left to right, enough for front and rear prongs to clear post. Allow shelf to be placed level at desired height. Insert front and rear shelf hooks into post slots simultaneously.

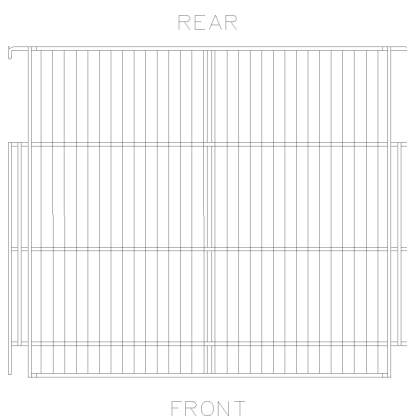

**Figure 35**

2. Install side product stops (as required). Insert right angle ends of product stops into front and rear post slots. Refer to Figure 36 ,

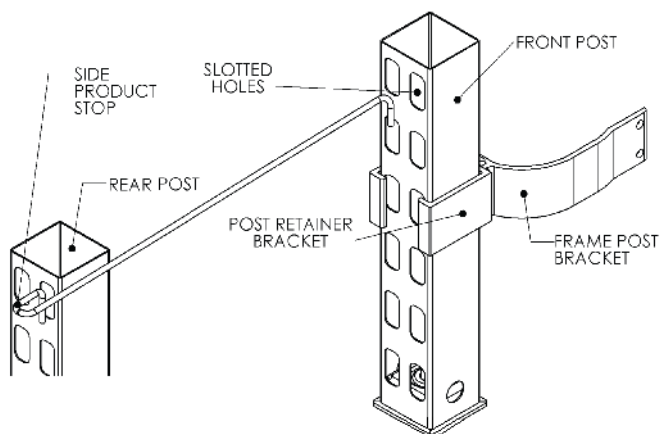

Figure 36

3. Install rear product stops (as required) after stocking shelves. Insert rear-product stop ends into rear post slots at desired height. R Refer to Figure 37 .

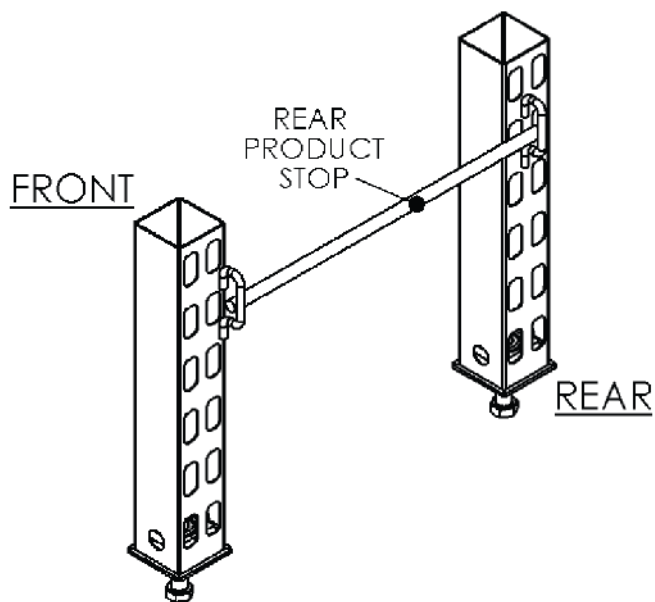

Figure 37

### Catalog Shelf Sizes

Standard Depths: 24" or 27"

Model	Standard Catalog Door Size	Actual Shelf Size
Model 401	23"	22-9/16" x 23"
	26-3/4"	26-5/16" x 26"
	28-3/4"	28-5/16" x 28"
	30-1/4"	29-13/16" x 30"
Model 101/2100	24"	23-5/16" x 24"
	26"	26-5/16" x 26"
	28"	28-5/16" x 28"
	30"	29-13/16" x 30"
Model 1001	23"	22-9/16" x 23"
	26-3/4"	26-5/16" x 26"
	28-3/4"	28-5/16" x 28"
	30-1/4"	29-13/16" x 30"

### Shelf Dimensions

1. Measure shelf from large diameter wire, left to right and front to back. Do not measure from prongs.
2. Shelf Tag Moulding is measured from left to right.
3. Indicate color, when ordering replacement tag.

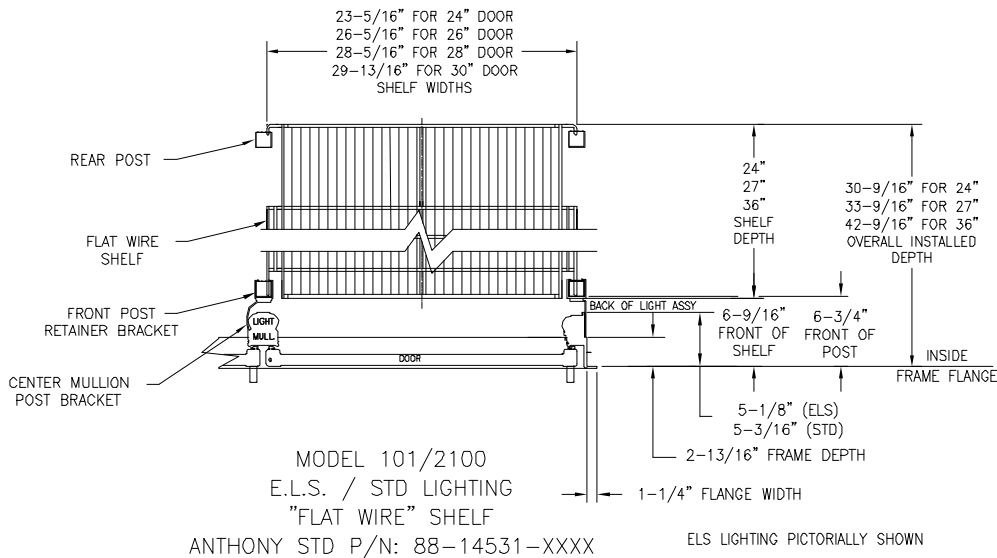

Figure 38 . Model 101/2100

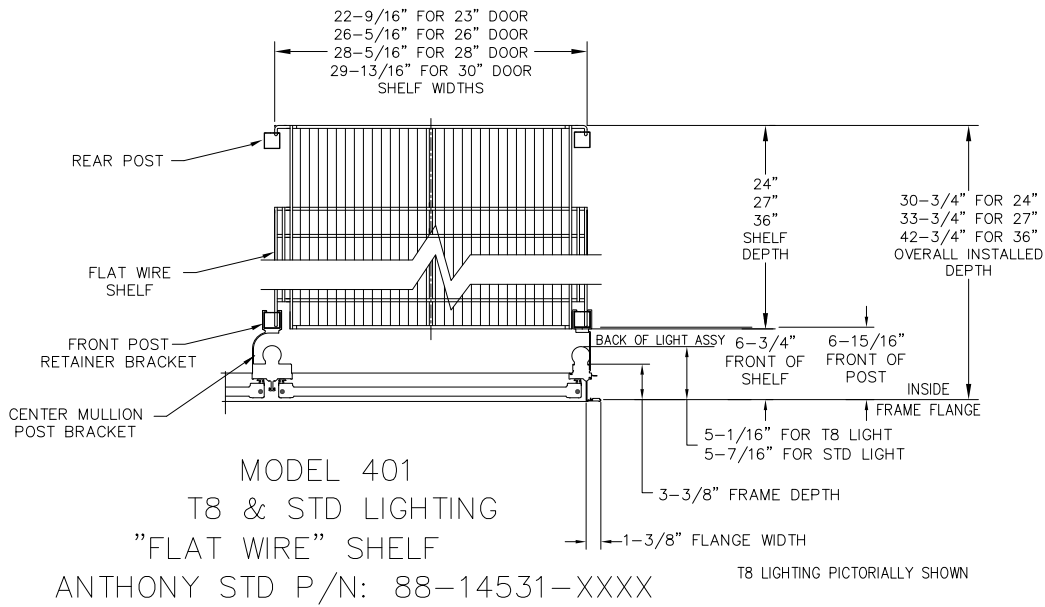

Figure 39 . Model 401



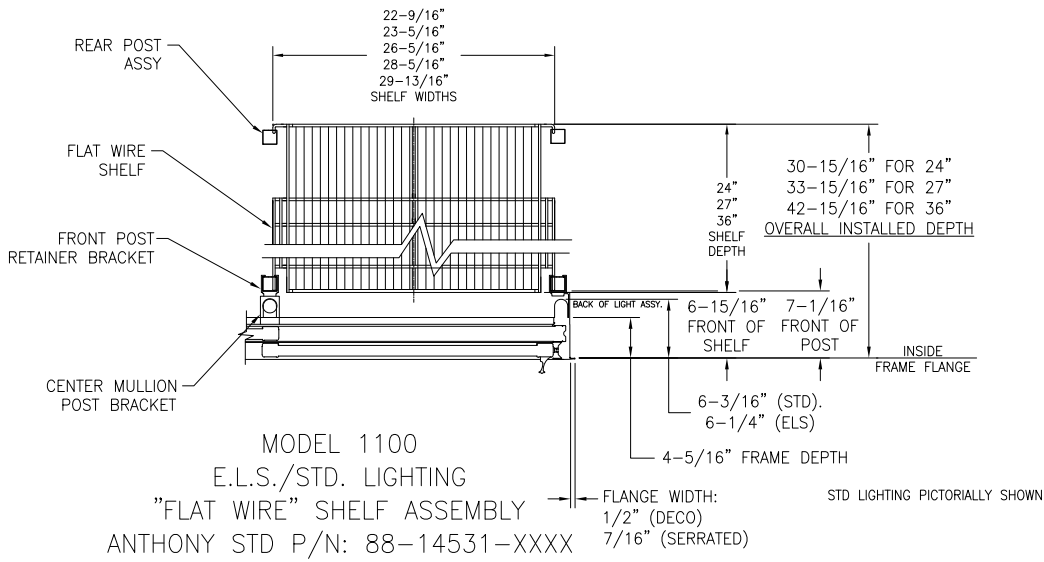

Figure 40 . Model 1100

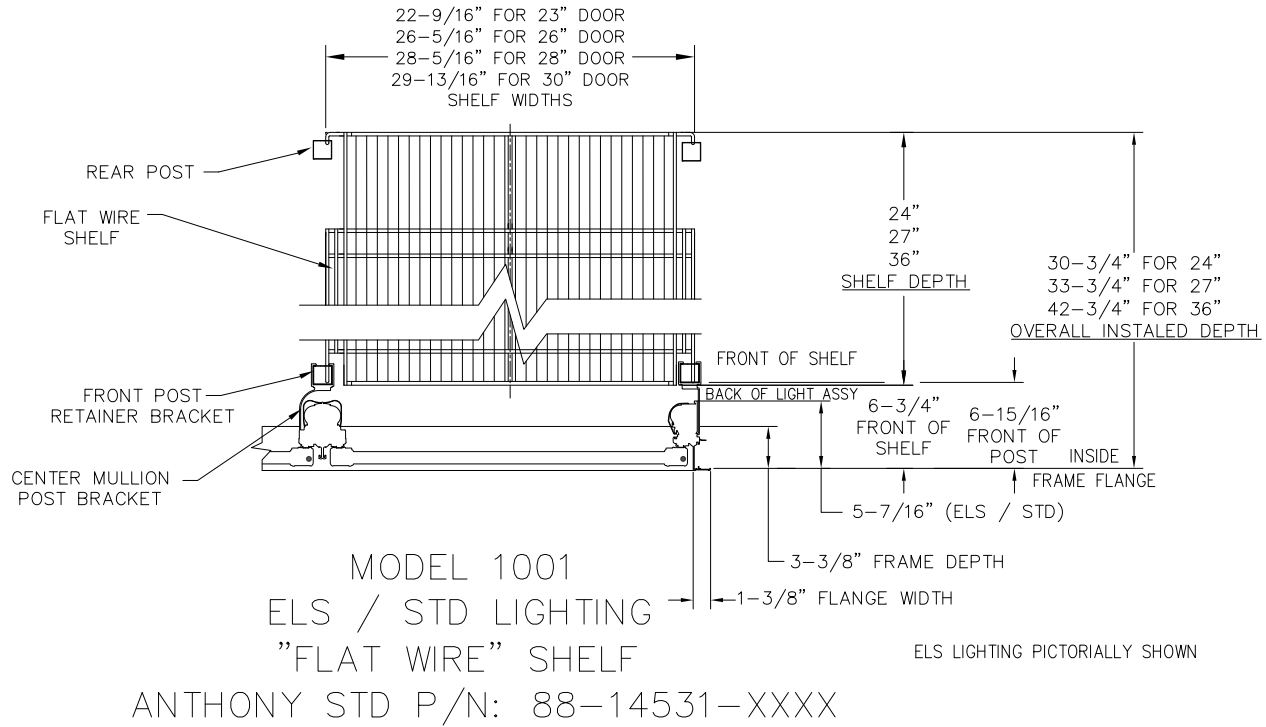

Figure 41 . Model 1001





12391 Montero Street, Sylmar, CA 91342  
800.772.0900 [www.anthonydoorintl.com](http://www.anthonydoorintl.com)

**99-18880-I001\_B**

# Document Revision History

## Revision History

Revision History			
A	1995		
B	May 5, 2011	SWatstein	

## Contributors

Contributors			
Sherman Watstein			
Ray Calderon			

Copyright © 2010 by  Anthony®

ALL rights reserved. Information in this document is subject to change without notice. Companies, names and data used in examples herein are fictitious unless otherwise noted. No part of this document may be reproduced or transmitted in any form or by any means, electronic or mechanical, for any purpose, without express permission of Anthony Manufacturing Co., Inc.