

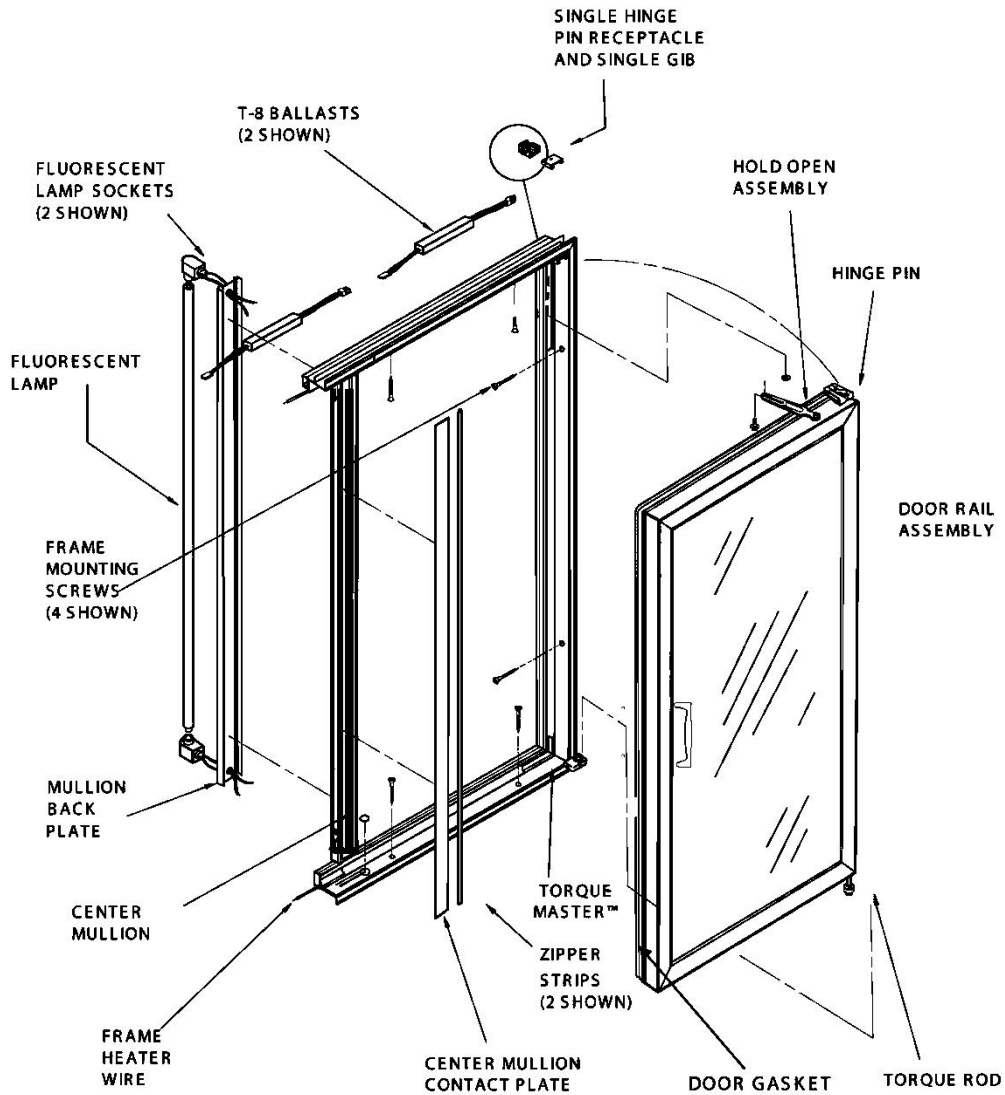

A DOVER COMPANY





101B, 210X, ELM, VSTB Installation Manual

99-16105-I001



Copyright © 2010 by

ALL rights reserved. Information in this document is subject to change without notice. Companies, names and data used in examples herein are fictitious unless otherwise noted. No part of this document may be reproduced or transmitted in any form or by any means, electronic or mechanical, for any purpose, without express permission of Anthony Manufacturing Co., Inc.

Anthony products identified in this manual are designed and certified to meet  or  for safety, and  for sanitation standards.

European products meet  requirements.

Each customer is responsible for final site approval.

TABLE OF CONTENTS

- 1. PRELIMINARY CONSIDERATIONS FOR DOOR AND FRAME SERVICING PROCEDURES4**
 - 1.1. Safety4
 - 1.2. Tools4
 - 1.3. Tips4
- 2. FRAME INSTALLATION AND SERVICE MAINTENANCE5**
 - 2.1. Shimming5
 - 2.2. To Install the Frame6
 - 2.3. Sealing the Frame7
 - 2.4. Frame Electrical Wiring Connections7
- 3. DOOR INSTALLATION8**
 - 3.1. To Install the Door Assembly8
 - 3.2. To Remove the Door Assembly9
 - 3.3. To Reverse the Door Swing 11
 - 3.3.1. Frame 11
 - 3.3.2. Door 12
- 4. TORQUEMASTER™ AND SAG ADJUSTMENT 13**
- 5. REVISION HISTORY PAGE 14**

1. PRELIMINARY CONSIDERATIONS FOR DOOR AND FRAME SERVICING PROCEDURES

1.1. Safety

Proper safety equipment includes:



Safety Glasses



Work Gloves



Work Shoes



NOTE: Turn off all electrical power prior to beginning work on the door or on any electrical equipment. Use extra caution when working with or around the door glass package.

NOTE: Do Not use power tools for the following procedures.

1.2. Tools

Tools required for this procedure include:

- | | |
|--------------------------------|--------------------------|
| • #2 Phillips-head screwdriver | Flat-head screwdriver |
| • Needle-nose pliers | Rubber or plastic mallet |
| • 7/16" and 1/2" Hand Wrench | 5/32" Hex Key |
| • Wire stripper and cutter | Soldering iron |
| • Heat Gun | Razor Knife |

1.3. Tips

- Complete replacement of wire assemblies is recommended whenever required. Splice wires only if necessary, using proper materials: such as electrical tape, wire nuts, flux core solder and heat shrink.
- Apply liquid soap to rail plastic covers and gaskets upon installation to facilitate insertion into mounting grooves.
- Keep doors and frames clean for product efficiency. This can also help reduce energy consumption and potential health hazards.
- Whenever binding gasket or plastic parts, use food grade silicone.
- Whenever replacing fluorescent lamps, always replace lamp covers as well.
- Always use the correct tool for the job to be performed. This ensures proper installation and minimizes safety risks.
- If there is any doubt about the work to be performed, consult with a certified technician or Anthony representative.
- Preventative maintenance is recommended to ensure product longevity.

2. FRAME INSTALLATION AND SERVICE MAINTENANCE

1. Read instructions completely before installing the frame.
 - Clearance between the frame sill and the case bottom or floor is mandated by local building codes.
 - Sill net opening must be a minimum of two inches in height
 - Sill must be completely level.
2. Before installing the frame, confirm the size of the net opening accommodates the finish frame. If the tolerances are too high, the net opening will have to be enlarged.
3. Check size of finished frame to net opening.
 - Subtract the frame height measurement from the net opening's height measurement.
 - Subtract the frame width measurement from the net opening's width measurement.
 - Divide each number in half. This is the amount of gap that will occur between the frame and the net opening.
4. If the gap between the frame and the net opening is greater than 1/16", shim the gap for a proper fit.
 - 2.1. Shimming
 1. Acquire sturdy, penetrable material, such as plywood. The thickness of the material should be wedge shaped or slightly less than the gap to be filled.
 2. Measure the gap length (height or width of frame) and cut the shim material to 1/16" less than the measured length.
 3. Install the shim using the same type of mounting hardware that will be used to install the frame. Be certain that the shim installation hardware will not interfere with the frame installation hardware
 4. If necessary, cut a second shim to the same length and install it in the opposite side of the net opening.

5. If the adjacent sides of the net opening need shimming, repeat the previous steps. Match the shim length to the frame sides of the net opening (less 1/16”).

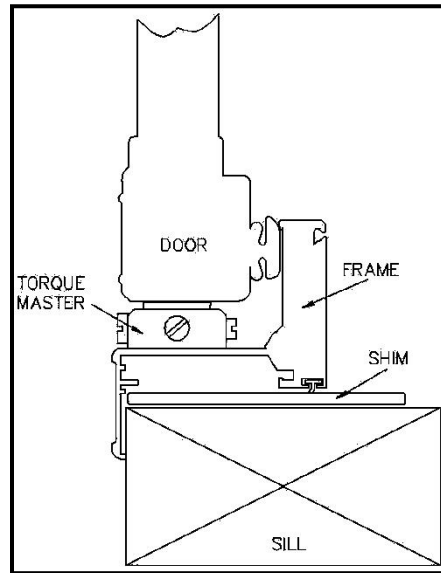

Anthony Door and Frame Cross-Section

2.2. To Install the Frame

1. Verify openings conform to net openings listed in price book or original order.
2. Insert the finished frame assembly into the net opening. **DO NOT** force the frame if the fit is too tight.
3. Insert a mounting screw into a mounting hole in each corner of the frame and tighten each screw until it is approximately a quarter inch from flush.
4. Check the frame is aligned properly or square.
 - Use a 16-foot measuring tape to measure diagonally one corner to the opposite and note the distance.
 - Measure the distance between the remaining two corners.
 - Both measurements should be the same, within a 1/16” difference.
5. Confirm the frame and frame flanges are vertically aligned to the wall surface around the net opening.
6. Place a level on the top flange of the header frame to check if it is horizontally aligned.
7. If the top of the header frame sags or bows, correct as necessary.
8. When the frame is aligned, tighten all mounting screws securely until each is flush to the frame surface.

NOTE: DO NOT over-tighten the screws, as this can cause the frame to become out of square.

9. Check entire frame to ensure installation is correct.

2.3. Sealing the Frame

The electrical connection at the Junction Box where the wires enter the frame, and where the wires enter the raceway in the frame must be sealed with silicone caulking at the time of installation.

NOTE: Use caulk and food grade silicone sealant to seal the gap between the frame and the surrounding wall, inside case, cooler or freezer. Not following these procedures can void Anthony's Service & Warranty on condensation and ice build-up issues.

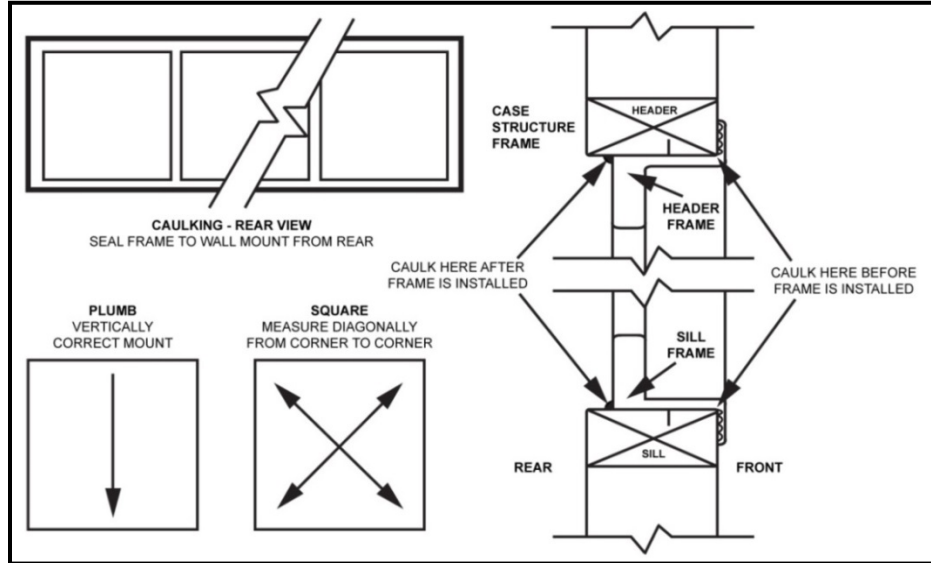

Frame Installation Reference

2.4. Frame Electrical Wiring Connections

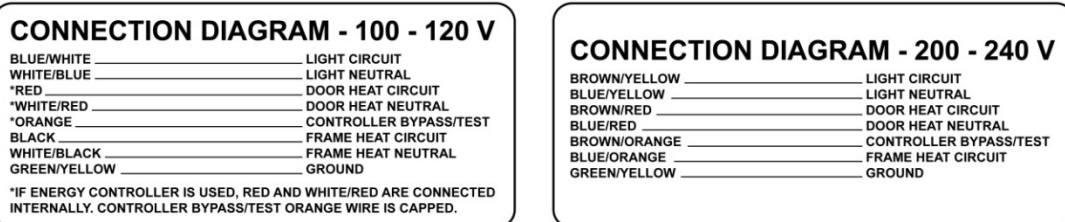

Wire Diagram Connection Label

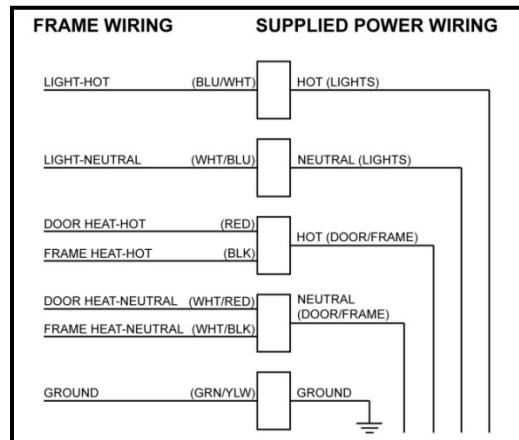

Wiring Diagram

The seven individual wires extending from the flexible conduit atop the frame, provide electrical power to various frame and door functions for the wiring diagram label, affixed to the frame header.

Using wire connectors, these wires should be grouped by the Hot wires (Circuit wires), the Neutral wires and the ground wire for connection to either the facility or the case power.

- Blue/White wire connects to the supplied Hot (or Lights Circuit Wire).
- White/Blue wire connects to the supplied Light neutral wire.
- Red and Black wires connect to the supplied Hot (or Door/Frame Heater Circuit Wire).
- White/Red and White/Black wires connect to the supplied neutral wire for Door/Frame Circuit.
- Green/Yellow wire connects to the supplied ground wire.

NOTE: Wiring for lights should have a separate circuit from the door/frame heater wiring circuit.

3. DOOR INSTALLATION

3.1. To Install the Door Assembly

1. Hold the door on each side, with the handle facing forward. Lift door, align torque rod to insert into TorqueMaster™ socket at base of frame.

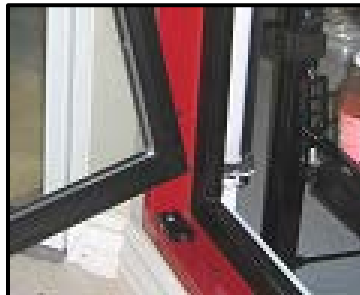

Insert Torque Rod

2. Engage door with hinge pin inserted into Gib (hinge pin plug) receptacle at top of frame. Push door into frame until hinge pin snaps in place.



Connect Hinge Pin

3. Insert the hold-open bolt through the elongated hold-open slot.

4. Insert the washer and the hold-open bolt into the frame mounting hole and tighten the bolt, use a 7/16" open-ended hand wrench.



Tighten Hold-Open Bolt

5. Set the door tension swing and correct the door alignment by adjusting the TorqueMaster™. (See TORQUEMASTER™ AND SAG ADJUSTMENT.)

NOTE: Exercise caution when handling the door.

NOTE: DO NOT use power tools when adjusting the TorqueMaster™.

NOTE: DO NOT over tighten hold-open bolt. Verify hold-open does not bind while sliding along the hold-open bolt. Adjust as necessary.

3.2. To Remove the Door Assembly

1. Release tension on TorqueMaster™ with a flat-head screwdriver. Turn the TorqueMaster™ front facing screw clockwise, until the door does not automatically close from an open position.



Release TorqueMaster Tension

2. Open door to access the hold open device, then loosen and remove hold-open detent bolt using a 7/16" hand wrench.



Remove Hold-Open Bolt

3. Retract the door to a near-closed position.

- Remove hinge pin plug from frame by inserting top-half of needle-nose pliers into the spring clip grip hole and the bottom half beneath the hinge pin shroud.



Disengage Hinge Pin

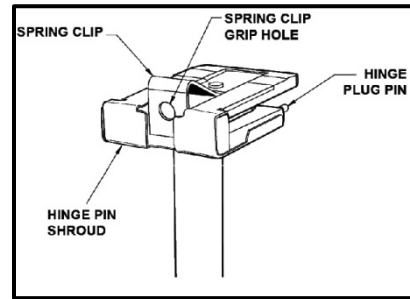

Hinge Pin Assembly

- Compress pliers to clamp down on hinge pin spring clip, then simultaneously pull the hinge pin away from the frame and pull the door top out.



Withdraw Away From Hinge Gib

- Lift door out of TorqueMaster™. Secure or lean door on its side against a stable surface.



Withdraw From Frame

3.3. To Reverse the Door Swing

Some doors are reversible. Remove the door from the frame first and then perform the following steps.

3.3.1. Frame

1. To remove Torquemaster, insert flat-head screwdriver into top center cutout in Torquemaster, and turn mounting screw counter-clockwise for less than ½ turn. Lift Torquemaster off frame.



Remove TorqueMaster

2. Pry off (underneath) plug cap from mounting hole, on opposite side of the doorframe with a flat-head screwdriver.



Remove Plug Gap

3. Set Torquemaster on opened mounting hole. Align the flanged corners of the mounting tabs with the SAG ADJUSTMENT screw facing the inside of the frame.



Mount TorqueMaster

4. Use the flat-head screwdriver and turn the Torquemaster mounting setscrew clockwise for ½ turn, to tighten the mounting flange and lock it in place.

5. Relocate and install the hold-open stand-offs and spacer into the opposite hold-open mount of the same doorframe.



Insert Stand-Off

3.3.2. Door

1. Access the hinge pin wire connections in the rail on the hinge side of the door assembly.
2. Disconnect the Hot, Neutral, and Ground wires of the hinge pin.

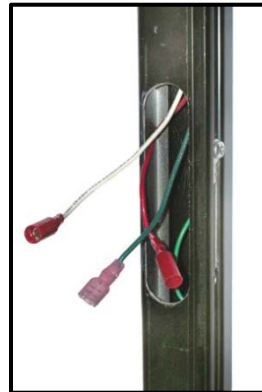

Hinge Pin Wire

3. Loosen and remove the hinge pin assembly from the top door rail.
4. Using a plastic mallet and a flat-head screwdriver, remove the torque rod from the bottom of the door assembly.

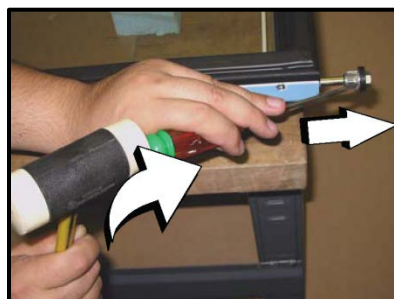

Remove Torque Rod

5. Reinstall the hinge pin and the torque rod into the opposite ends of the door assembly.
6. Reconnect the hinge pin wires and confirm all connections.

7. Check and confirm torque rod and hinge pin are correctly installed.
8. Reinstall the door into the frame per the door installation procedures.

4. TORQUEMASTER™ AND SAG ADJUSTMENT

The TorqueMaster™ regulates the door alignment and the door closing tension.

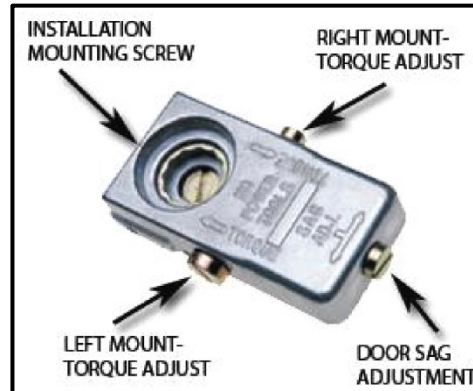

Remove Torque Rod

1. Use a flathead screwdriver to adjust the torque rod tension, by turning the outside screw on the TorqueMaster™.
 - Turn counter-clockwise to increase tension.
 - Turn clockwise to decrease the tension.
2. Adjust the door sag to square the door in the frame by turning the screw that is marked SAG ADJ. (sag adjustment), on the end of the TorqueMaster™, until the door is aligned square in opening.
 - Turn counter-clockwise to raise handle side of door.
 - Turn clockwise to lower the handle side of door.

5. REVISION HISTORY PAGE

REV	ORIGINATOR	DESCRIPTION OF CHANGE	EFFECTIVE DATE
A			
B			
C	BGee		November 2006
D	SWatstein		30 March 2010
E	SWatstein		27 May 2010
F	S. Fisher	Reformat from Framemaker to Word	12/18/2012
G	S. Fisher	Inserted 'Sealing the Frame' section	03/13/2014