

Model Type(s): 101, 2100, 1001, 401
Item: Standard Shelving Installation Instructions - Flat Wire Rear Entry Style (November 1995 - To Present)
Effective Date: January 31, 2008
Doc ID: IN-0023_B

PROCEDURE:

1. Install front shelf posts (refer to Figure 1).
2. Fit top and bottom safety-retaining brackets over top post with offset keyway retainer at back of post (Opposite side of post slots).
3. Post retaining bracket spring slides into female frame post bracket from the top down (Figure 3).
4. Slotted holes in front and rear posts now face toward the back wall (inside of case). Refer to Figure 4.
5. Install post stabilizer bars (Figure 5) on the top and bottom of all posts, front to rear, before installing shelves. Stabilizer bars have a forked end that inserts into elongated holes in front and rear posts.

NOTE: Rear Posts have additional holes on seam side for stabilizer.

6. Level front and rear posts at bottom of post.

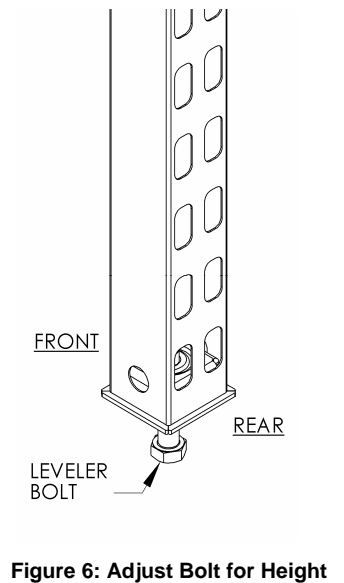
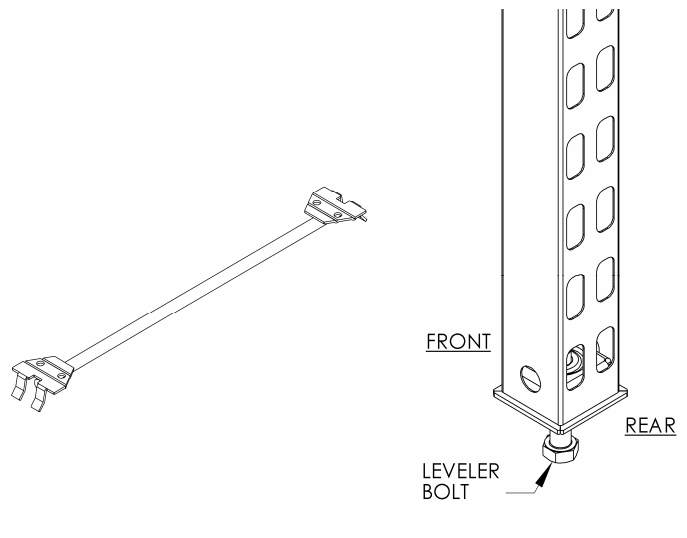
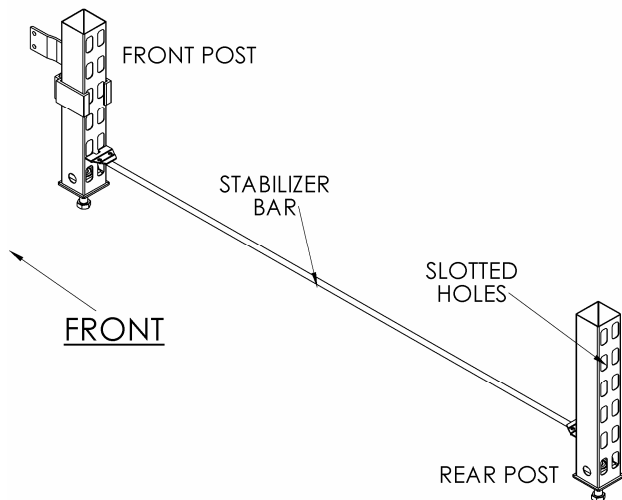
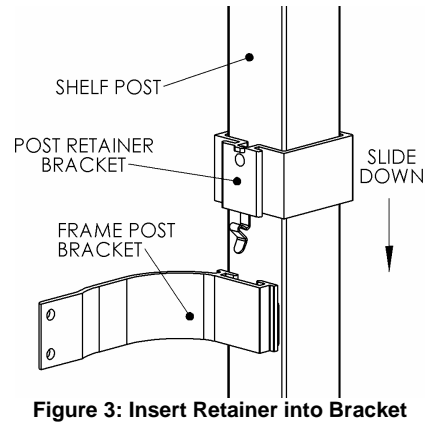
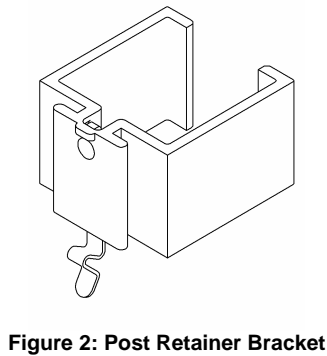
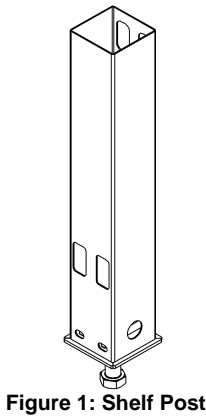

7. Shelf Installation

NOTE: SHELF WEIGHT LIMIT OF 200 LBS (90.7 KG).

NOTE: INDIVIDUAL POST WEIGHT LIMIT 1050 LBS (476 KG). Posts must have intermediate supports (post locators) installed. Shelf heights to be located for merchandising and load dispersion.

- a. Angle/Tilt shelf (Figure 7) left to right, enough for front and rear prongs to clear post. Allow shelf to be placed level at desired height. Insert front and rear shelf hooks into post slots simultaneously.
- b. Install side product stops (as required). Insert right angle ends of product stops into front and rear post slots. Refer to Figure 8,
- c. Install rear product stops (as required) after stocking shelves. Insert rear-product stop ends into rear post slots at desired height. Refer to Figure 9.

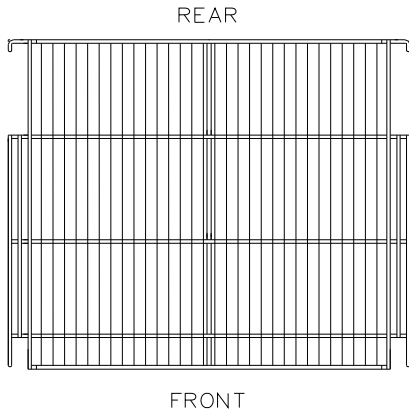

Figure 7: Overhead View of Shelf

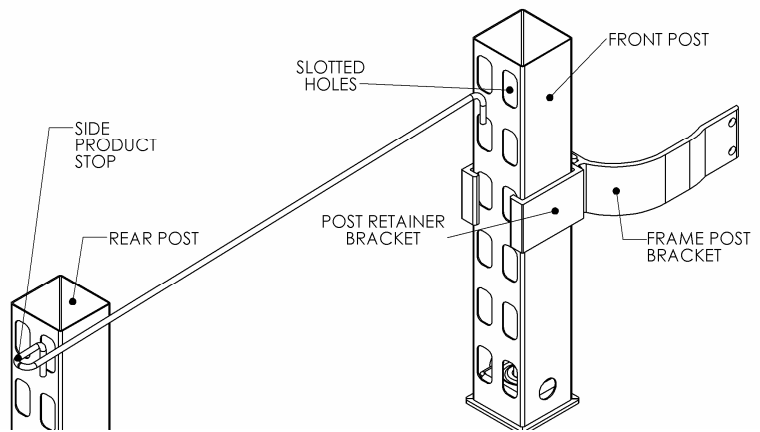

Figure 8: Side Product Stop

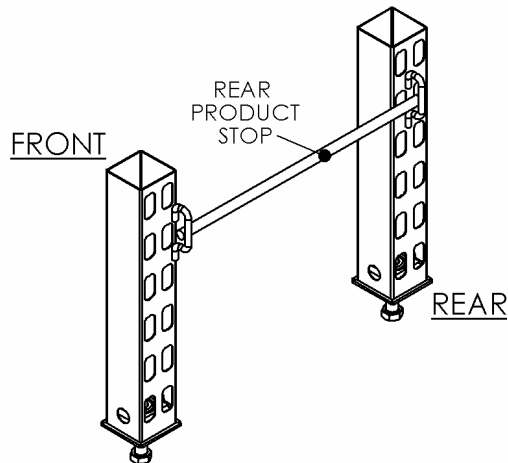

Figure 9: Rear Product Stop

8. Catalog Shelf Sizes

Standard Depths: 24" or 27"

| <u>Catalog Shelf Size</u> | <u>Actual Size</u> | <u>Catalog Shelf Size</u> | <u>Actual Size</u> |
|---------------------------|--------------------|---------------------------|--------------------|
| 401 and 1001 | | Model 100 | |
| 23" | 22-9/16" x 27" | 24" | 23-5/16" x 27" |
| 26-3/4" | 26-5/16" x 27" | | |
| 28-3/4" | 28-5/16" x 27" | Model 100 | |
| 30-1/4" | 29-13/16" x 27" | 30" | 29-13/16" x 27" |

9. Shelf Dimensions

- a. Measure shelf from large diameter wire, left to right and front to back. Do not measure from prongs.
- b. Shelf Tag Moulding is measured from left to right.
- c. Indicate color, when ordering replacement tag.

